

# 250D-9

Performance Enhanced For stage IV

MOVING YOU FURTHER

**HYUNDAI HEAVY INDUSTRIES**



■ Photo may include optional equipment

 **HYUNDAI**  
HEAVY INDUSTRIES EUROPE

# Your satisfaction is **our priority!**

Hyundai introduces a new line of **9-series** diesel forklift trucks.  
The newly designed 4 wheel Heavy duty counterbalance trucks provide  
every operator comfortable driving, increased productivity and easy maintenance.

## **New Diesel Forklift with Proven Quality and Advanced Technology**

- **Maximum performance**
- **Spacious operator's cab**
- **Load weight indicator**
- **OPSS System for safe operation**
- **Easy serviceability**



■ Photo may include optional equipment

# High Efficiency & Optimal Performance



Powerful engine and high technology systems provide you with enhanced performance and highest productivity.

**250D-9**



## Cummins QSL Engine

204kW / 2,200 rpm  
124kgf.m / 1,500 rpm

### Powerful Engine

The six cylinders turbo-charged engine is built for power, reliability and economy. This engine meets EPA Tier 4 and EU stage IV emission regulation.

### Variable Geometry Turbo

Unique sliding nozzle design controls EGR flow and boosts response at all engine speeds - avoids the need for twin turbo complexity

### New CM2350

Improved microprocessor and memory

### Clean Crankcase Filter

Removes crankcase emissions and eliminates oil drips or mist for ultra-clean engine operation



### ZF Full-automatic Transmission

Full-automatic transmission gives easy, convenient handling and soft, smooth shifting. The operator can select two kinds of automatic modes. (1st <—> 3rd, 2nd <—> 3rd)  
Improved Torque converter with stator free wheel provides you fuel efficiency compared with old model for 4%.

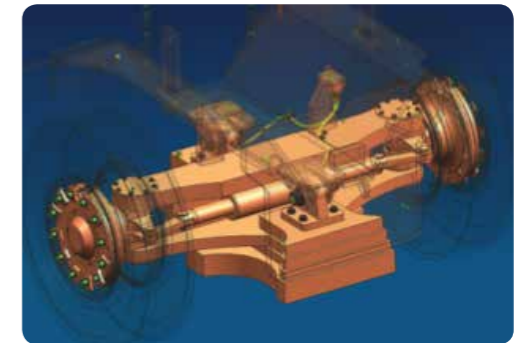

### Fully Hydrostatic Power Steering

The hydraulic steering system always guarantees smooth and flexible steering, preventing over-run and kick-back.

### Load Sensing System

Only flow required on cylinders is supplied. It makes energy saving. (No excessive flow)

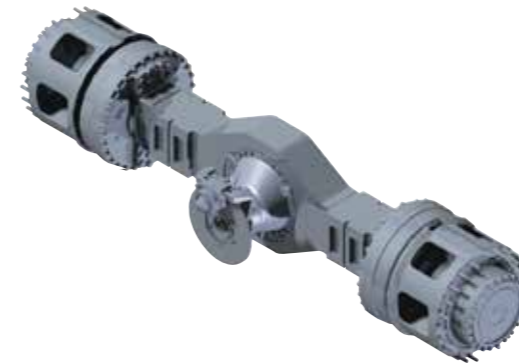

### Kessler Durable drive axle

The planetary reduction drive axle smoothly delivers desired torque to the drive wheels.



### Wet Disc Brake System

The wet disc brake system is virtually maintenance free and is enclosed to protect from dust and water.



### Increased mast tilting angle

Utilizing the mast tilting angle of 12 degrees forward and 10 degrees backward, the operator can perform loading and unloading jobs safely and rapidly.



Max. Gradeability (loaded)		Max. Travel Speed (Unloaded)	
Model	%	Model	Km / h
250D-9	31.2	250D-9	31.5

### Faster Travel Speed and Gradeability

The powerful high-output engine provides greater acceleration, better gradeability and faster travel speed on any tough terrain or slope.

# Best Convenience & Optimised Ergonomics



The ergonomically designed cabin provides full support and comfort to the operator.

**250D-9**



■ Photo may include optional equipment

## Spacious Operator Cabin

The newly designed cabin was conceived for more space, a wider field of view and operator comfort.



**MP3 CD Player & Remote Control**



**Bluetooth Hands Free Socket (Option)**



**Centralized Instrument switch Panel**



## Luxury (Air-suspension+Heat+HeadRest) seat (Option)

An attractive and adjustable seat, based on a human engineering design, provides great comfort, safety and durability.



## Quick Response of Operating Control Levers

Only minimal operator's effort is required for precise, safe and productive control.

(5-Lever, 6-Function : Standard)

(5-Lever, 7-Function : Option)



## Ergonomically positioned pedals

Based on human engineering the accelerator, brake and inching pedals are optimally positioned for the operator's convenience.

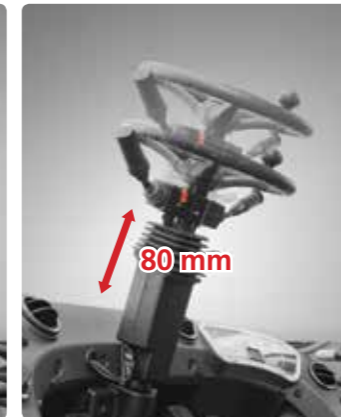

## Adjustable steering column

Steering handle is adjustable depending on the operator's body shape. Adjustability of steering column makes you more comfortable.



## High-output Air Conditioner & Heater

An air conditioner with integrated the condenser is mounted on upper side of the cabin to make a wide room in the cabin. And an air conditioner with high-output and heater always provide you with comfortable environment when you work.

# Advanced Safety



The safely designed driver's space makes your operating more comfortable.

**250D-9**



### Engine Control Mode

According to operating load, the operator can select engine mode by changing side panel switch.

STD Mode :

Fuel reduction mode for light-duty operating load

POWER Mode :

Heavy-duty or operating at slope



### Adjustable Engine Low Idle RPM

While engine runs, low idle rpm can be increased by unit of 25rpm and it keeps previously set rpm when engine restarts.

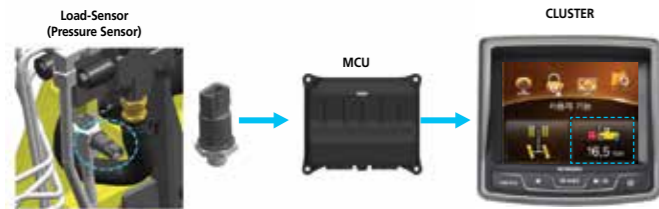

### Load indicator

The optional load indicator displays the load weight in the monitor. The load sensor reduces the time to check loaded weight and the alarm alerts the driver when overloaded.

### OPSS (Operator Presence Sensing System)

When the operator is not in the seat all mast and drive movements are impossible.

Lift Lock Tilt Lock Drive Lock



■ Photo may include optional equipment



### Up-to-date Cooling System

The minimum fuel consumption and low noise are available by applying hydraulic cooling fan sensing intake air temperature, transmission oil temperature, coolant temperature and hydraulic temperature.



### Cabin Tilting Automatic System

Cabin tilting automatic system makes servicing of all power train components quick and easy. An electrically assisted hydraulic actuated cylinder tilts operator cabin to left side about 65 degrees for easy access to inside of truck components.

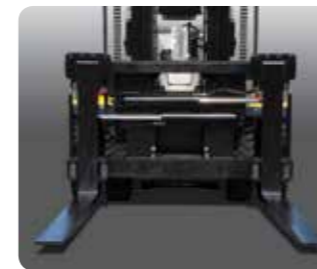

### Highly durable Carriage

The carriage is very strong cause of applying the high tensile structural steel which has a excellent durability.



### Large footboard & Handle

Wide "open" step offers convenience and safety when entering and exiting the truck.



### Excellent Night Work

- Various position of work lamp provides the operator more comfortable and safe operating environments.  
- Front : fender(2), mast(4) - Rear : cab(2)  
- LED Rear Combination Lamp



# Fast and Easy Maintenance

An ideal arrangement of components ensures easy access and convenience for maintenance.

**250D-9**



## Large Engine Hood

Highly accessible engine compartment assures fast and efficient maintenance.



## Easy Change Air Cleaner

This air filter is readily accessible for cleaning or replacement.



## Cabin Air Fresh Filter

The internal pressure is maintained to be slightly higher than that of outside to exclude dust and to reduce noise levels.

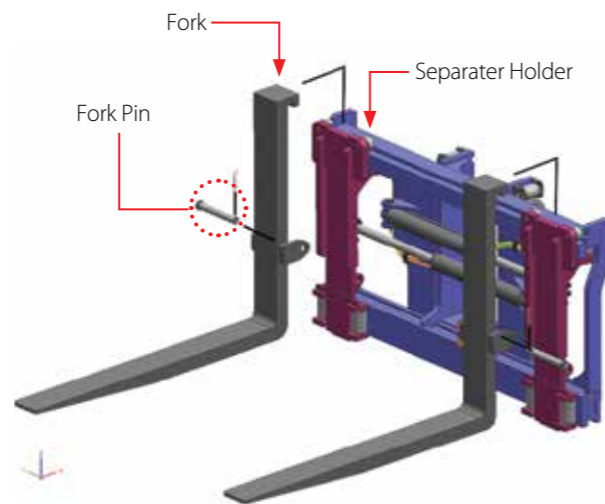

## Separator holder type Fork Carriage (Option)

To improve handling and easily switch forks and other attachment Separator holder system is adopted as option. It is possible to install various attachments like coil ram easily.



## Rear View Camera

The rear view camera makes the operation more easy and convenient. And it supports 4 camera channels.



■ Photo may include optional equipment



## Master Switch

A master switch disconnects the battery power to protect the electrical system from excess electrical drainage.



## Maintenance Management display



## Engine Start Limit

## Dimension

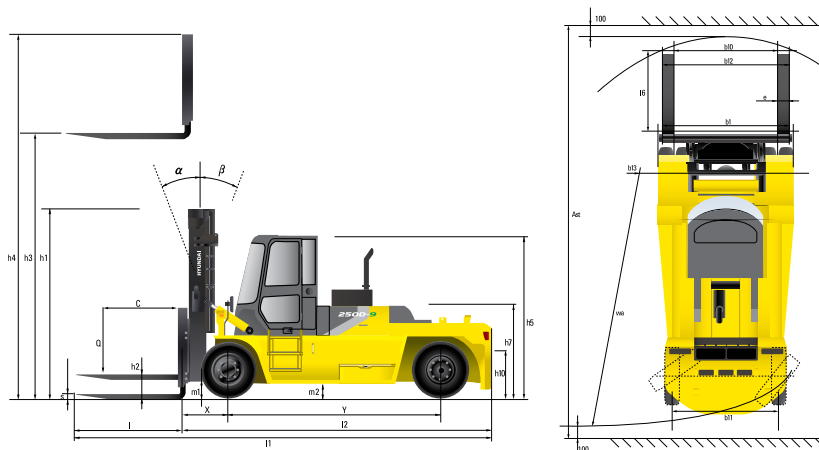

## Mast Specification

Mast Type	Maximum Fork Height (mm)	Overall Height Lowered (mm)	Tilt Angle (deg) Forward / Backward	Load Capacity (1,200 mm LC) (kg)	Truck Weight Unloaded (kg)
V345	3,476	3,593	12 / 10	25,000	36,630
* V400	4,030	3,877	12 / 10	25,000	37,021
V450	4,530	4,127	12 / 10	25,000	37,271
V500	5,030	4,377	12 / 10	25,000	37,526
V550	5,530	4,627	12 / 10	24,950	37,788
V600	6,030	4,877	12 / 10	24,950	38,379
V650	6,530	5,127	12 / 10	24,450	38,686
V700	7,030	5,377	12 / 10	23,550	38,968

## Load Capacity

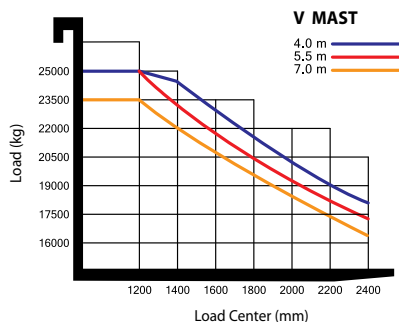

## Optional Items

- Fork (L x W x T) (mm)  
2,450 x 250 x 110 (standard) / 2,700 x 250 x 110 / 3,150 x 250 x 110 / 3,650 x 250 x 110 / 3,700 x 250 x 110
- MCV : 6-SPOOL
- Air compressor
- Integrated fork positioner (independent) + side shift (standard)
- Terminal West fork carriage
- Hands free
- Beacon lamp

\* Standard and optional equipment may vary per country. Contact your Hyundai dealer for more information.  
 \* The photos may include attachments and optional equipment that are not available in your area.  
 \* Materials and specifications are subject to change without advance notice.  
 \* All imperial measurements rounded off to the nearest pound or inch.

PLEASE CONTACT



## Specification

Identification		
1.1	Manufacturer	HYUNDAI
1.2	Type	250D-9
1.3	Drive: Electric, Diesel, LPG Gas	DIESEL
1.4	Type of operation: hand, pedestrian, standing, seated, order-picker	seated
1.5	Load capacity (standard)	Q (kg) 25,000
1.6	Load center distance	c (mm) 1,200
1.8	Load distance, center of drive axle to forks	x (mm) 1,112
1.9	Wheelbase	y (mm) 4,250
Weights		
2.1	Service weight	kg 37,021
2.2	Axle loading, loaded front / rear	kg 57,277 / 41,744
2.3	Axle loading, unloaded front / rear	kg 18,647 / 18,374
Wheels, Chassis		
3.1	Tires : solid rubber (V), superelastic (SE), pneumatic (P), polyurethane (PE)	Pneumatic
3.2	Tires size, front (Ø x width)	14.00 - 24 - 32PR
3.3	Tires size, rear (Ø x width)	14.00 - 24 - 32PR
3.5	Wheels, number front rear (x = driven wheels)	4 x 2
3.6	Track width, front	b10 (mm) 2,212
3.7	Track width, rear	b11 (mm) 2,140
Basic Dimensions		
4.1	Mast / fork carriage tilt forward / backward	degrees 12 / 10
4.2	Lowered mast height (standard)	h1 (mm) 3,877
4.3	Free lift	h2 (mm) 0
4.4	Lift height	h3 (mm) 4,030
4.5	Extended mast height	h4 (mm) 5,837
4.7	Overhead load guard (cab) height	h5 (mm) 3,223
4.8	Seat height / standing height	h7 (mm) 2,150
4.12	Coupling height	h10 (mm) 528
4.19	Overall length	l1 (mm) 8,812
4.20	Length to face of forks	l2 (mm) 6,362
4.21	Overall width	b1 (mm) 3,050
4.22	Fork dimensions L x W x T	s / e / l (mm) 2,450 x 250 x 110
4.24	Fork carriage width	b3 (mm) 2,950
4.31	Ground clearance, loaded, under mast	m1 (mm) 300
4.32	Ground clearance, centre of wheelbase	m2 (mm) 250
4.33	Aisle width for pallets 1000 x 1200 crossways (L x W)	Ast (mm) 9,626
4.34	Aisle width for pallets 800 x 1200 lengthways (W x L)	Ast (mm) 9,626
4.35	Turning radius	Wa (mm) 5,864
4.36	Smallest pivot point distance	(mm) 2,030
Performance Data		
5.1	Travel speed, loaded / unloaded	km/h 31.5
5.2	Lift speed, loaded / unloaded	mm/s 250 / 280
5.3	Lowering speed, loaded / unloaded	mm/s 400 / 300
5.5	Drawbar pull, loaded	kg 20,500
5.7	Gradient performance, loaded	% 31.2
5.10	Service brake	Wet, Hydraulic
Engine		
6.1	Engine manufacturer / type	Cummins QSL
6.2	Engine power acc. To ISO 1585	kW 204
6.3	Rated speed	1/min 2,200
6.4	No. of cylinder / cubic capacity	/cm <sup>3</sup> 6 / 8,898
6.5		ℓ/h 25
Other Details		
8.1	Type of drive control	Power Shift
8.2	Operating pressure (system / attachments)	kg.f/cm <sup>2</sup> 240 / 160
8.3	Oil volume for attachments	ℓ/min 270
8.4	Sound level at driver's ear according to DIN 12 053	db(A) 76.2