



We build a better future

■ Photo may include optional equipment

HYUNDAI LPG FORKLIFT TRUCKS - Applied Tier 4 Engine

60L/70L-7A

VERKOOP • VERHUUR • TWEEDEHANDS • SERVICES



EUROTRADING MORTIER

Torhoutbaan 181 - 8480 ICHTEGEM
Tel. 050 21 73 60 - Fax 050 21 61 33

www.eurotradingmortier.be

HYUNDAI
HEAVY INDUSTRIES EUROPE

VERKOOP • VERHUUR • TWEEDEHANDS • SERVICES



EUROTRADING MORTIER

Torhoutbaan 181 - 8480 ICHTEGEM
Tel. 050 21 73 60 - Fax 050 21 61 33

www.eurotradingmortier.be



NEW criterion of Forklift Trucks

Hyundai introduces with its 7A-series a new line of LPG forklift trucks. Excellent power and performance improves your business profitability.

VERKOOP • VERHUUR • TWEDEHANDS • SERVICES



EUROTRADING MORTIER

Torhoutbaan 181 - 8480 ICHTEGEM
Tel. 050 21 73 60 - Fax 050 21 61 33

www.eurotradingmortier.be



■ Photo may include optional equipment

The new master on your job-site!

Smooth running, efficient and ergonomically designed, 60/70L-7A series are made to meet your needs.

70 kW / 2,300 rpm



Powerful Engine

GM 4.3L V6 Engine

Market approved quality of GM 4.3L V6 engine ensures incomparable performance, durability and additional value to the machine. Powerful and efficient engine provides excellent fuel consumption and excellent torque improved operator's comfort. (EPA/CARB Tier-IV Certified)

Fast and stable performance

Being able to quickly raise and lower the mast, as well as tilting forward and backward, the truck provides you the best operational conditions during loading/unloading operations. When the truck is fully loaded, mast lowering speed is carefully controlled to ensure safety by the down control valve.

Mast (Lift and Tilt) Lock System is standard.

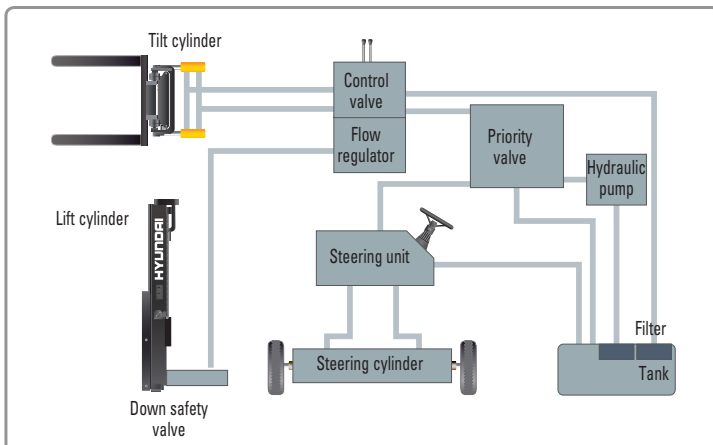

State-of-the-art hydraulic system

The latest designed, large-capacity hydraulic system including a low-noise control valve shortens reaction time during operation and improves both efficiency and durability.



Fully hydrostatic power steering

A hydraulic steering system always guarantees smooth and flexible steering, preventing overrun and steering wheel kick-back.

■ Photo may include optional equipment



Increased mast tilting angle

A mast tilting angle of 15 degrees forward and 10 degrees backward gives the operator a safe and rapid platform for loading and unloading jobs.

Faster Travel Speed & Grade-ability

The powerful high-output engine provides greater acceleration, better grade-ability and faster travel speed on any tough terrain or slope.



Grade-ability (Loaded)

60L-7A : 45.6%
70L-7A : 40.6%

Travel speed (Unloaded)

60L-7A : 22.4 km/h
70L-7A : 22.5 km/h

Ergonomic operator friendly compartment design!

A design based on human engineering relieves fatigue and increases operator's efficiency.

Operator friendly gauges and water-resistant monitor panel



- 1 Parking brake lamp
- 2 Directional indicators
- 3 Engine oil warning lamp
- 4 Transmission oil temperature warning lamp
- 5 Battery charging warning lamp
- 6 Air cleaner filter warning light
- 7 Working light indicator
- 8 Seat belt warning
- 9 Water temperature gauge
- 10 OPSS warning (option)
- 11 Hour meter
- 12 Engine check lamp
- 13 Brake oil warning lamp



Easily adjustable suspension seat

An attractive and adjustable seat with armrests, based on a human engineering design, provides great comfort, safety and durability.



High visibility for safe operation

The operator is able to work with increased safety and accuracy due to a wider view mast.



Ergonomic positioned pedals

Based on human engineering, the accelerator, brake and inching pedals are optimally positioned for operator's convenience.



Cup holder & console box

Additional storage spaces are located inside the operating space for operator's convenience.



Quick Response of Operating Control Levers

Only minimal operator's effort is required for precise, safe and productive control.

■ Photo may include optional equipment



Adjustable steering wheel

Steering wheel with horn button can be adjusted by a lever on the right-hand side for the most comfortable operator position.



Easy and safe shift lever

A single lever on the left side of the steering column gives the operator fast and easy control of speed and travel direction. The engine can only be started in case of neutral position of this lever.



Multi-function switch lever

A multi-functional switch lever gives easy access to lights and horn.

Enhanced safety through high durability!

Safety and durability are priorities in the design of the equipment.

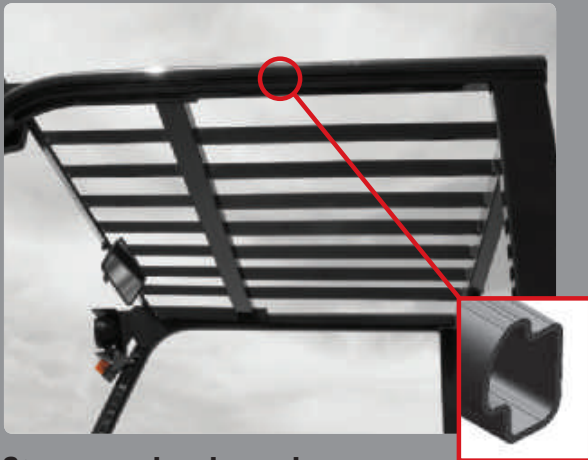

Strong overhead guard

The safety overhead guard meets ISO 6055 regulations and protects the operator during hazardous jobs.



Parking Brake

Toggle type parking brake requires less efforts from the operator to set.

Highly durable split type drive axle

The planetary reduction drive axle smoothly delivers desired torque to the drive wheels.

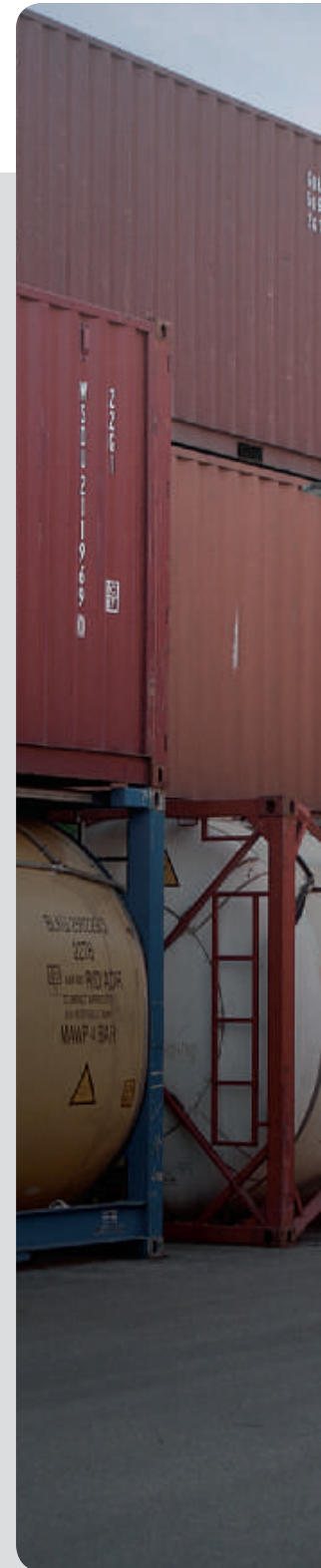

OPSS (Operator Presence Sensing System)

No mast or drive movement is possible when the operator is not seated in normal position.

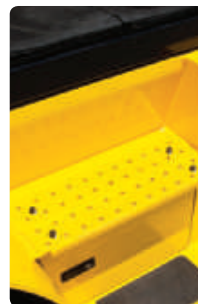

Large footstep & Handle

Wide "open" step ensures easy and safe access to the operator's seat

■ Photo may include optional equipment

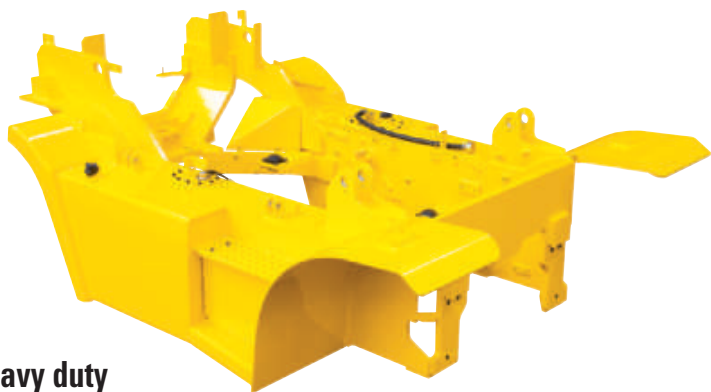

Heavy duty single unit frame

Heavy duty single unit type frame, designed on the basis of accurate structural analysis, guarantees durability and safety.



Bright, protected headlights

Bright, protected headlights are positioned for increased visibility in dark environments.

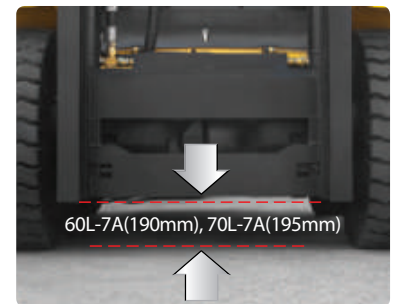

Ground clearance

The engine and transmission are assembled horizontally and positioned high in the frame to protect valuable components during operations on rugged surface.

Centralized design for easy service!

An ideal arrangement of components ensures easy access and convenience during maintenance.



Large Open Engine Hood

Highly accessible engine compartment assures fast and efficient maintenance.



Easy change air cleaner

The air filter is readily accessible for cleaning or replacement.



Up-to-date cooling system



Brake Fluid Reservoir with low level indicator

When the brake fluid level reaches minimum, a warning lamp on the cluster is activated.



Easy Maintenance oil check

The T/M oil level can be checked easily without any disassembly.



Expansion bellows

The expansion bellows absorbs vibration and reduces noise generated from the exhaust gas system to extend the life span.



Grease fittings

Grease fittings are installed for fast access to steering axle center pin when performing your service checks.





■ Photo may include optional equipment



Maintenance Free Battery



Large tool box
Additional tool box located under footstep for operator's convenience.



Easy-to-access reservoir tank



Wing Cover Locking System

Mast Specifications

Model	Mast Type	Maximum Fork height (mm)	Overall height (mm)			Free Lift (mm)		Tilt Angle (deg)		Load Capacity without side shift at 600 mm LC (kg)	Load Capacity with side shift at 600 mm LC (kg)	Truck Weight (Unloaded) (kg)	
			Lowered	Extended		Without Load Backrest	With std Load Backrest	Fwd	Bwd				
				Without Load Backrest	With std Load Backrest								
60L-7A	2/ Stage limited free lift	V270	2,730	2,365	3,911	4,020	140	140	15	10	6,000	6,000	8,779
		*V300	3,030	2,515	4,211	4,320	140	140	15	10	6,000	6,000	8,826
		V330	3,330	2,665	4,511	4,620	140	140	15	10	6,000	6,000	8,874
		V350	3,530	2,765	4,711	4,820	140	140	15	10	6,000	6,000	8,906
		V370	3,730	2,865	4,911	5,020	140	140	15	10	6,000	6,000	8,938
		V400	4,030	3,015	5,211	5,320	140	140	15	10	6,000	6,000	8,994
		V450	4,530	3,315	5,711	5,820	140	140	15	10	6,000	6,000	9,221
		V500	5,030	3,565	6,211	6,320	140	140	15	10	6,000	5,850	9,301
		V550	5,530	3,815	6,711	6,820	140	140	15	10	6,000	5,650	9,381
	V600	6,030	4,065	7,211	7,320	140	140	15	10	6,000	5,500	9,459	
	3/ Stage full free lift	TF450/TS450	4,560	2,565	5,765	5,805	1,360	1,275	15	10	6,000	5,750	9,430
		TF500/TS500	5,060	2,765	6,265	6,305	1,560	1,475	15	10	6,000	5,600	9,522
		TF560/TS560	5,600	2,965	6,805	6,845	1,760	1,675	15	10	5,950	5,400	9,633
TF600/TS600		6,060	3,165	7,265	7,305	1,960	1,875	15	10	5,750	5,250	9,720	

*Standard : Hook-on Type Fork & Carriage

Model	Mast Type	Maximum Fork height (mm)	Overall height (mm)			Free Lift (mm)		Tilt Angle (deg)		Load Capacity without side shift at 600 mm LC (kg)	Load Capacity with side shift at 600 mm LC (kg)	Truck Weight (Unloaded) (kg)	
			Lowered	Extended		Without Load Backrest	With std Load Backrest	Fwd	Bwd				
				Without Load Backrest	With std Load Backrest								
70L-7A	2/ Stage limited free lift	V270	2,730	2,365	3,911	4,020	140	140	15	10	7,000	7,000	9,457
		*V300	3,030	2,515	4,211	4,320	140	140	15	10	7,000	7,000	9,506
		V330	3,330	2,665	4,511	4,620	140	140	15	10	7,000	7,000	9,552
		V350	3,530	2,765	4,711	4,820	140	140	15	10	7,000	7,000	9,584
		V370	3,730	2,865	4,911	5,020	140	140	15	10	7,000	7,000	9,616
		V400	4,030	3,015	5,211	5,320	140	140	15	10	7,000	7,000	9,672
		V450	4,530	3,315	5,711	5,820	140	140	15	10	7,000	6,900	9,900
		V500	5,030	3,565	6,211	6,320	140	140	15	10	7,000	6,700	9,979
		V550	5,530	3,815	6,711	6,820	140	140	15	10	7,000	6,500	10,059
	V600	6,030	4,065	7,211	7,320	140	140	15	10	6,800	6,350	10,137	
	3/ Stage full free lift	TF450/TS450	4,560	2,565	5,765	5,805	1,360	1,275	15	10	7,000	6,600	10,095
		TF500/TS500	5,060	2,765	6,265	6,305	1,560	1,475	15	10	6,900	6,400	10,187
		TF560/TS560	5,600	2,965	6,805	6,845	1,760	1,675	15	10	6,700	6,200	10,298
TF600/TS600		6,060	3,165	7,265	7,305	1,960	1,875	15	10	6,500	6,050	10,386	

*Standard : Hook-on Type Fork & Carriage

Load Capacity

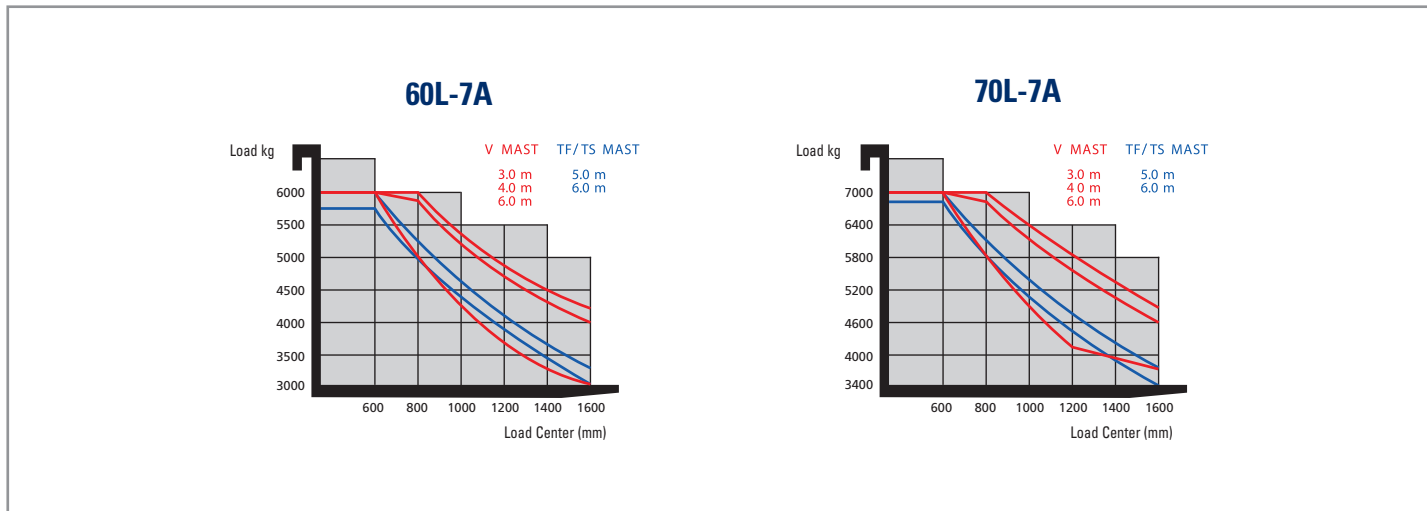

Various Attachments

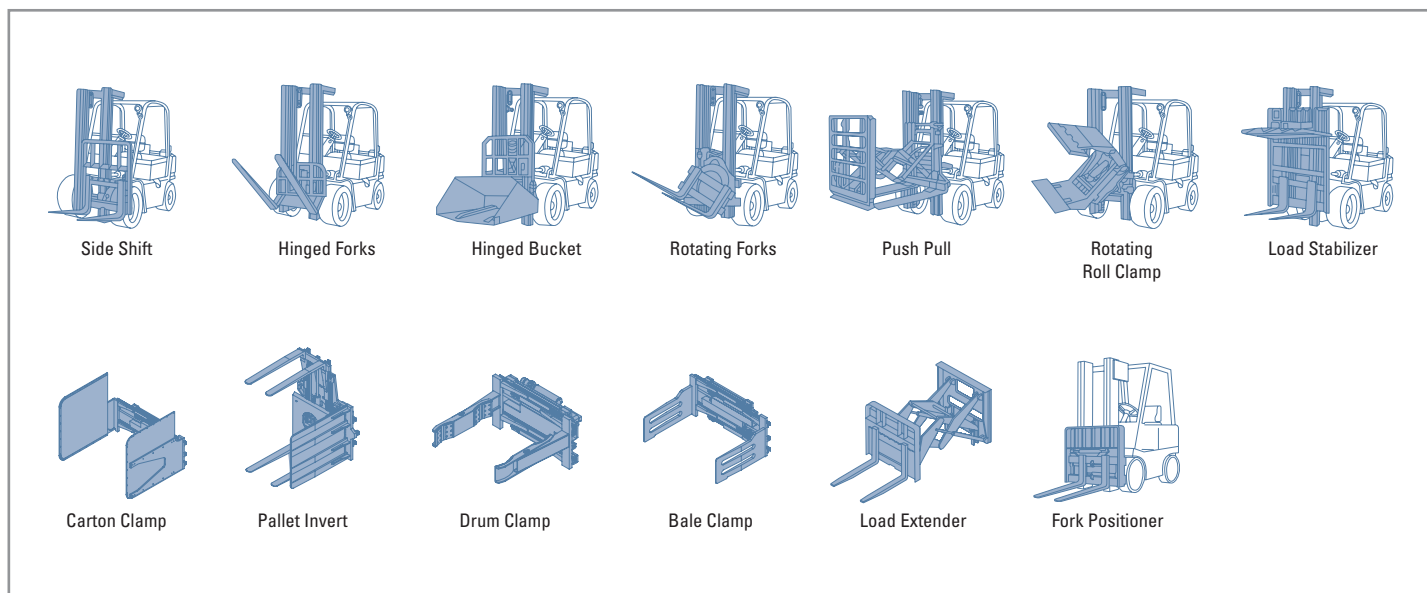

Optional Items

· **FORK (L x W x T) (mm)**
1,350 / 1,500 / 1,800 / 2,000 / 2,400

· **FORK EXTENDERS**
1,800 / 2,000 / 2,200 / 2,300

· **TIRE SOLID NON-MARKING**

· **SEAT SEATBELT, ARM REST, HIP REST**

· **INTERNAL PIPING**

· **CABIN & HEATER CABIN, HEATER**

· **MUFFLER HORIZONTAL**

· **LPG TANK CLAMP : DUAL**

· **MASTER SWITCH**

· **BEACON LAMP**

· **HAZARD SWITCH**

· **MCV 3-SPOOL / 4-SPOOL / 5-SPOOL**

· **INTEGRAL FORK POSITIONER CARRIAGE**

· **INTEGRAL SIDE SHIFT CARRIAGE**

· **INTEGRAL SIDE SHIFT WITH FORK POSITIONER CARRIAGE**

Dimensions

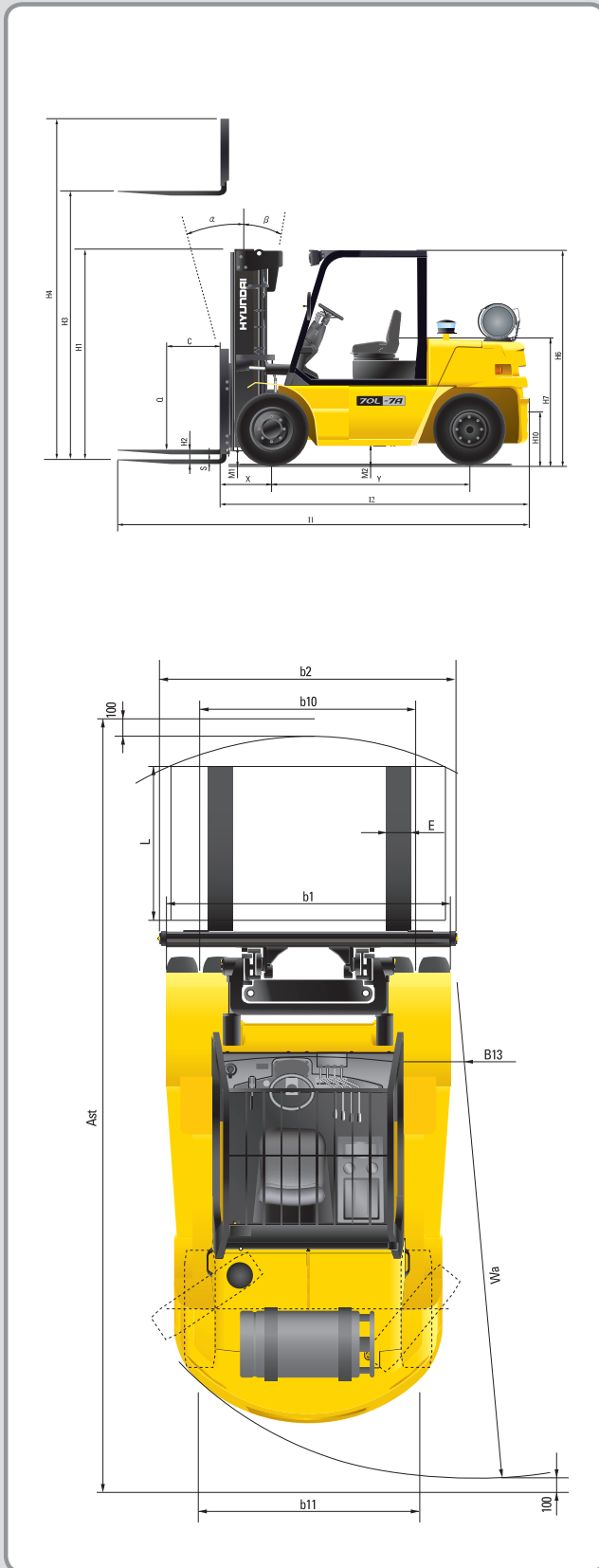

Specifications

Identification				
1.1	Manufacturer	Hyundai	Hyundai	
1.2	Type	60L-7A	70L-7A	
1.3	Drive: Electric, Diesel, LPG Gas	LPG	LPG	
1.4	Type of operation: hand, pedestrian, standing, seated, order-picker	seated	seated	
1.5	Load capacity (standard)	Q (kg)	6,000	7,000
1.6	Load center distance	c (mm)	600	600
1.8	Load distance, center of drive axle to forks	x (mm)	615	615
1.9	Wheelbase	y (mm)	2,300	2,300
Weights				
2.1	Service weight	kg	8,862	9,430
2.2	Axle loading, loaded front / rear	kg	13,159 / 1,703	14,564 / 1,866
2.3	Axle loading, unloaded front / rear	kg	3,990 / 4,832	3,867 / 5,564
Wheels, chassis				
3.1	Tires: solid rubber, superelastic, pneumatic, polyurethane		Pneumatic	Pneumatic
3.2	Tires size, front		8.25-15	8.25-15
3.3	Tires size, rear		8.25-15	8.25-15
3.5	Wheels, number front / rear (X = driven wheels)		4x/2	4x/2
3.6	Track width, front	b10 (mm)	1,578	1,578
3.7	Track width, rear	b11 (mm)	1,604	1,604
Basic dimensions				
4.1	Mast / fork carriage tilt forward / backward	degrees	15 / 10	15 / 10
4.2	Lowered mast height (standard)	h1 (mm)	2,515	2,515
4.3	Free lift	h2 (mm)	140	140
4.4	Lift height (standard)	h3 (mm)	3,030	3,030
4.5	Extended mast height (standard)	h4 (mm)	4,320	4,320
4.7	Overhead load guard (cab) height	h5 (mm)	2,500	2,500
4.8	Seat height / standing height	h7 (mm)	1,395	1,395
4.12	Coupling height	h10 (mm)	425	425
4.19	Overall length	l1 (mm)	4,770	4,820
4.20	Length to face of forks	l2 (mm)	3,570	3,620
4.21	Overall width	b1 (mm)	2,087	2,087
4.22	Fork dimensions (hook type) LxWxT	s / e / l (mm)	65 x 150 x 1,200	65 x 150 x 1,200
4.23	Fork carriage ISO 2328, class / type A,B		Class IV	Class IV
4.24	Fork carriage width	b12 (mm)	2,068	2,068
4.31	Ground clearance, loaded, under mast	m1 (mm)	190	195
4.32	Ground clearance, centre of wheelbase	m2 (mm)	220	220
4.33	Aisle width for pallets 1000 x 1200 crossways (L x W)	Ast (mm)	5,136	5,185
4.34	Aisle width for pallets 800 x 1200 lengthways (W x L)	Ast (mm)	5,336	5,385
4.35	Turning radius	Wa (mm)	3,321	3,370
4.36	Smallest pivot point distance	b13 (mm)	1,224	1,224
Performance data				
5.1	Travel speed, unloaded	km/h	22.5	22.4
5.2	Lift speed, loaded / unloaded	mm/s	420 / 420	420 / 420
5.3	Lowering speed, loaded / unloaded	mm/s	500 / 450	500 / 450
5.5	Drawbar pull, loaded	kg	6,827	6,861
5.7	Gradient performance, loaded / unloaded	%	45.6	40.6
5.10	Service brake		Foot : Hydraulic	Foot : Hydraulic
Engine				
6.1	Engine manufacturer / type		GM 4.3L V6	GM 4.3L V6
6.2	Engine power acc. To ISO 1585	kW	70	70
6.3	Rated speed	1/min	2,300	2,300
6.4	No. of cylinder / cubic capacity	/cm ³	6 / 4,294	6 / 4,294
Other details				
8.1	Type of drive control		Power Shift	Power Shift
8.2	Operating pressure (attachments)	bar	185	185
8.3	Hydraulic oil flow (attachments)	ℓ/min	94	94
8.4	Sound level at driver's ear according to DIN 12053	db(A)	82	82

* Standard and optional equipment may vary. Contact your Hyundai dealer for more information. The machine may vary according to international standards.

* The photos may include attachments and optional equipment that are not available in your area.

* Materials and specifications are subject to change without advance notice.

* All imperial measurements rounded off to the nearest pound or inch.

PLEASE CONTACT

HYUNDAI
HEAVY INDUSTRIES EUROPE
MATERIAL HANDLING

VERKOOP • VERHUUR • TWEEDEHANDS • SERVICES
EUROTRADING MORTIER
Torhoutbaan 181 - 8480 ICHTEGEM
Tel. 050 21 73 60 - Fax 050 21 61 33
www.eurotradingmortier.be

Hyundai Heavy Industries Europe N.V.

VOSSENDAAL 11, 2440 GEEL, BELGIUM TEL: (32) 14-56-2200 FAX: (32) 14-59-3405